

Amplified Pressure Sensors

-10 cm H₂O to 120 cm H₂O Pressure Sensor

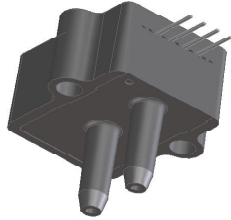

Features

- 4 Volt ratiometric output
- Temperature Compensated
- Calibrated Zero and Span

Applications

- Medical Instrumentation
- Respiratory Breathing

General Description

This Amplified Output pressure sensor is based upon a proprietary technology to compensate all errors. This model provides a calibrated amplified output with superior output characteristics. Output characteristics are tested at pressure and temperature and then digitally compensated using a proprietary 3D mapping scheme. In addition the sensor utilizes a silicon, micromachined, stress concentration enhanced structure to provide a very linear output to measured pressure.

These calibrated and temperature compensated sensors give an accurate and stable output over a wide temperature range. This series is intended for use with non-corrosive, non-ionic working fluids such as air, dry gases and the like.

The output of the device is ratiometric to the supply voltage over a supply voltage range of 4.5 to 5.5 volts.

Physical Dimensions

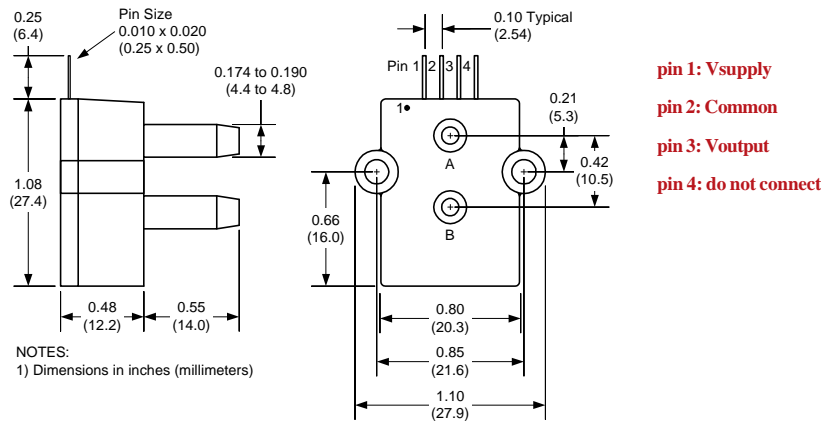

Pressure Sensor Characteristics Maximum Ratings

Supply Voltage V_S	+4.5 to +5.5 Vdc
Common-mode pressure	10 psig
Lead Temperature (soldering 2-4 sec.)	250°C

Environmental Specifications

Temperature Ranges	
Compensated	see specification
Operating	-25 to 85° C
Storage	-40 to 125° C
Humidity Limits	0 to 95% RH (non condensing)

Standard Pressure Ranges

Part Number	Operating Pressure	Compensated Range ⁵	Proof Pressure	Burst Pressure
120 cmH2O-D1-4V	-10 to 120 cm H2O	to 50° C	300 cmH2O	600 cmH2O
120 cmH2O-D1-P4V	-10 to 120 cm H2O	-25 to 85° C	300 cmH2O	600 cmH2O

Equivalent Circuit

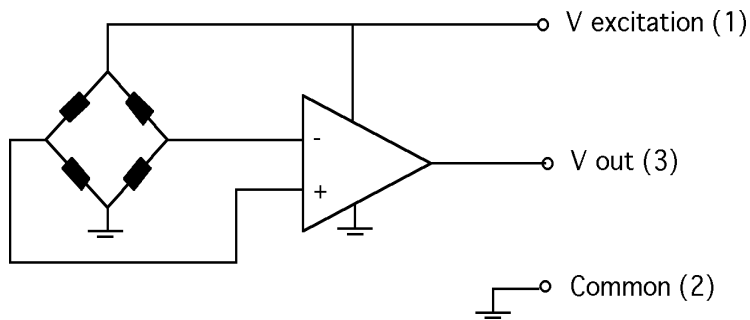

Performance Characteristics for 120 cmH2O-D1-P4V

Parameter, note 1	Minimum	Nominal	Maximum	Units
Operating Range, pressure	-10		120	cmH2O
Output Voltage, @120 cmH2O	4.40	4.5	4.6	volt
Output Voltage @ zero pressure	0.30	0.35	0.40	volt
Output Voltage @-10 cmH2O	0.23	0.28	0.33	volt
Offset Temperature Shift (-25 to 85°C), note 2			±1.0	%span
Linearity, hysteresis error, note 4		0.05	±0.25	%fs
Span Shift (-25 to 85°C), note 2			±1.0	%span

Performance Characteristics for 120 cmH2O-D1-4V

Parameter, note 1	Minimum	Nominal	Maximum	Units
Operating Range, pressure	-10		120	cmH2O
Output Voltage, @120 cmH2O	4.40	4.5	4.6	volt
Output Voltage @ zero pressure	0.30	0.35	0.40	volt
Output Voltage @-10 cmH2O	0.23	0.28	0.33	volt
Offset Temperature Shift (5°C-50°C), note 2			±1.0	%span
Linearity, hysteresis error, note 4		0.05	±0.25	%fs
Span Shift (5°C-50°C), note 2			±1.0	%span

Specification Notes

NOTE 1: ALL PARAMETERS ARE MEASURED AT 5.0 VOLT EXCITATION, FOR THE NOMINAL FULL SCALE PRESSURE AND ROOM TEMPERATURE UNLESS OTHERWISE SPECIFIED. PRESSURE MEASUREMENTS ARE WITH POSITIVE PRESSURE APPLIED TO PORT B.

NOTE 2: SHIFT IS RELATIVE TO 25°C.

NOTE 3: SHIFT IS WITHIN THE FIRST HOUR OF EXCITATION APPLIED TO THE DEVICE.

NOTE 4: MEASURED AT ONE-HALF FULL SCALE RATED PRESSURE USING BEST STRAIGHT LINE CURVE FIT.

NOTE 5: THE VOLTAGE ADDED TO THE OFFSET VOLTAGE AT FULL SCALE PRESSURE. NOMINALLY THE OUTPUT VOLTAGE RANGE IS 0.25 TO 4.25 VOLTS FOR MINUS TO PLUS FULL SCALE PRESSURE.

All Sensors reserves the right to make changes to any products herein. All Sensors does not assume any liability arising out of the application or use of any product or circuit described herein, neither does it convey any license under its patent rights nor the rights of others.