

MILLIVOLT OUTPUT PRESSURE SENSORS

Low Pressure (1" H₂O to 30" H₂O) Sensors

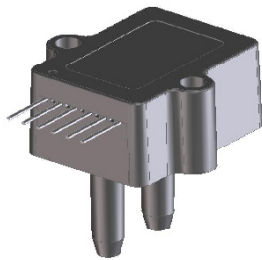

Features

- 0 to 1" H₂O to 0 to 30" H₂O Pressure Ranges
- Temperature Compensated
- Calibrated Zero and Span

Applications

- Medical Instrumentation
- Environmental Controls
- HVAC

General Description

The Millivolt Output pressure sensor is based upon a proprietary technology to reduce all output offset or common mode errors. This model provides a calibrated millivolt output with superior output offset characteristics. Output offset errors due to change in temperature, stability to warm-up, stability to long time period, and position sensitivity are all significantly reduced when compared to conventional compensation methods. In addition the sensor utilizes a silicon, micromachined, stress concentration enhanced structure to provide a very linear output to measured pressure.

These calibrated and temperature compensated sensors give an accurate and stable output over a wide temperature range. This series is intended for use with non-corrosive, non-ionic working fluids such as air, dry gases and the like.

The output of the device is ratiometric to the supply voltage and operation from any D.C. supply voltage up to +16 V is acceptable.

Physical Dimensions

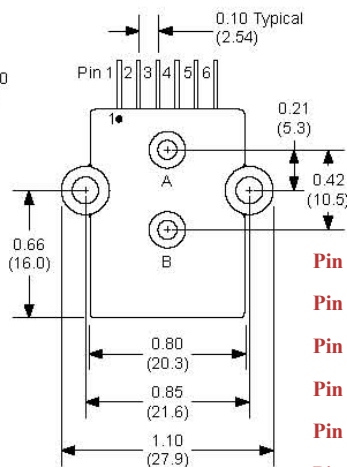
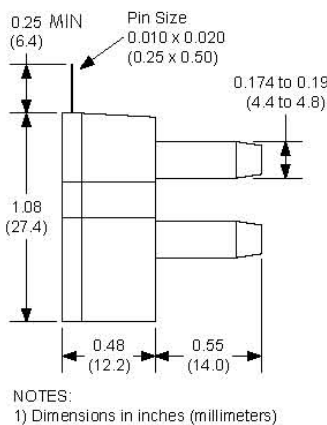

- Pin 1: N/C**
- Pin 2: +V supply**
- Pin 3: +Vout**
- Pin 4: -Vsupply**
- Pin 5: -Vout**
- Pin 6: N/C**

Equivalent Circuit

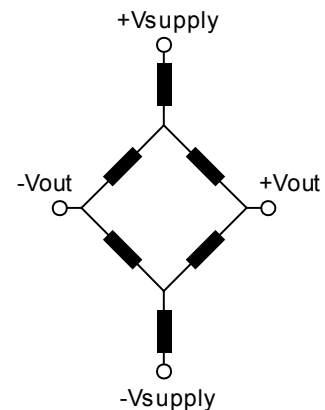

Input Resistance 4.5 k ohm
Output Resistance 1.5 k ohm

Approvals

MKT	DATE	MFG	DATE	ENG	DATE	QA	DATE
<input type="checkbox"/> As Is <input type="checkbox"/> With Change		<input type="checkbox"/> As Is <input type="checkbox"/> With Change		<input type="checkbox"/> As Is <input type="checkbox"/> With Change		<input type="checkbox"/> As Is <input type="checkbox"/> With Change	



Pressure Sensor Ratings

Supply Voltage V_s , max	16 Vdc
Common-mode pressure	-10 to +10 psig
Lead Temperature, max (soldering 2-4 sec.)	250°C

Environmental Specifications

Temperature Ranges	
Compensated	0 to 50(70)° C
Operating	-25 to 85° C
Storage	-40 to 125° C
Humidity Limits	0 to 95% RH (non condensing)

Standard Pressure Ranges

Part Number	Operating Pressure	Nominal Span	Proof Pressure	Burst Pressure
1 INCH-D-MV	0 - 1 "H2O	10 mV	100 "H2O	200 "H2O
2 INCH-D-MV	0 - 2 "H2O	10mv	100 "H2O	200 "H2O
5 INCH-D-MV	0 - 5 "H2O	20 mV	200 "H2O	300 "H2O
10 INCH-D-MV	0 - 10 "H2O	20 mV	200 "H2O	300 "H2O
20 INCH-D-MV	0 - 20 "H2O	20 mV	200 "H2O	500 "H2O
30 INCH-D-MV	0 - 30 "H2O	20 mV	200 "H2O	800 "H2O

Performance Characteristics for 1 INCH-D-MV

Parameter, note 1	Minimum	Nominal	Maximum	Units
Operating Range, differential pressure	--	1.0	--	"H2O
Output Span, @ 1"H2O, note 5	9.0	10.0	11.0	mV
Offset Voltage @ zero differential pressure	--	--	±500	uV
Offset Temperature Shift (0°C-50°C), note 2	--	--	±250	uV
Offset Warm-up Shift, note 3	--	--	±100	uV
Offset Position Sensitivity (1g)	--	--	±50	uV
Offset Long Term Drift (one year)	--	--	±200	uV
Linearity, hysteresis error, note 4	--	0.05	0.25	%fs
Full Scale Shift (0°C-50°C), note 2	--	--	±200	uV

Performance Characteristics for 2 INCH-D-MV

Parameter, note 1	Minimum	Nominal	Maximum	Units
Operating Range, differential pressure	--	2.0	--	"H2O
Output Span, note 5	9.0	10.0	11.0	mV
Offset Voltage @ zero differential pressure	--	--	±500	uV
Offset Temperature Shift (0°C-50°C), note 2	--	--	±250	uV
Offset Warm-up Shift, note 3	--	--	±100	uV
Offset Position Sensitivity (1g)	--	--	±50	uV
Offset Long Term Drift (one year)	--	--	±200	uV
Linearity, hysteresis error, note 4	--	0.05	0.25	%fs
Full Scale Shift (0°C-50°C), note 2	--	--	±200	uV

Performance Characteristics for 5 INCH-D-MV

Parameter, note 1	Minimum	Nominal	Maximum	Units
Operating Range, differential pressure	--	5.0	--	"H2O
Output Span, note 5	19.0	20.0	21.0	mV
Offset Voltage @ zero differential pressure	--	--	±500	uV
Offset Temperature Shift (0°C-50°C), note 2	--	--	±150	uV
Offset Warm-up Shift, note 3	--	--	±50	uV
Offset Position Sensitivity (1g)	--	--	±10	uV
Offset Long Term Drift (one year)	--	--	±100	uV
Linearity, hysteresis error, note 4	--	0.05	0.25	%fs
Full Scale Shift (0°C-50°C), note 2	--	--	±200	uV

Performance Characteristics for 10 INCH-D-MV

Parameter, note 1	Minimum	Nominal	Maximum	Units
Operating Range, differential pressure	--	10.0	--	"H2O
Output Span, note 5	19.0	20.0	21.0	mV
Offset Voltage @ zero differential pressure	--	--	±500	uV
Offset Temperature Shift (0°C-70°C), note 2	--	--	±150	uV
Offset Warm-up Shift, note 3	--	--	±50	uV
Offset Position Sensitivity (1g)	--	--	±5	uV
Offset Long Term Drift (one year)	--	--	±100	uV
Linearity, hysteresis error, note 4	--	0.05	0.25	%fs
Full Scale Shift (0°C-70°C), note 2	--	--	±200	uV

Performance Characteristics for 20 INCH-D-MV

Parameter, note 1	Minimum	Nominal	Maximum	Units
Operating Range, differential pressure	--	20.0	--	"H2O
Output Span, note 5	19.0	20.0	21.0	mV
Offset Voltage @ zero differential pressure	--	--	±500	uV
Offset Temperature Shift (0°C-70°C), note 2	--	--	±150	uV
Offset Warm-up Shift, note 3	--	--	±50	uV
Offset Position Sensitivity (1g)	--	--	±5	uV
Offset Long Term Drift (one year)	--	--	±100	uV
Linearity, hysteresis error, note 4	--	0.05	0.25	%fs
Full Scale Shift (0°C-70°C), note 2	--	--	±200	uV



Performance Characteristics for 30 INCH-D-MV

Parameter, note 1	Minimum	Nominal	Maximum	Units
Operating Range, differential pressure	--	30.0	--	"H ₂ O
Output Span, note 5	19.0	20.0	21.0	mV
Offset Voltage @ zero differential pressure	--	--	±500	uV
Offset Temperature Shift (0°C-70°C), note 2	--	--	±150	uV
Offset Warm-up Shift, note 3	--	--	±50	uV
Offset Position Sensitivity (1g)	--	--	±5	uV
Offset Long Term Drift (one year)	--	--	±100	uV
Linearity, hysteresis error, note 4	--	0.05	0.25	%fs
Full Scale Shift (0°C-70°C), note 2	--	--	±200	uV

Specification Notes

NOTE 1: ALL PARAMETERS ARE MEASURED AT 12.0 VOLT EXCITATION, FOR THE NOMINAL FULL SCALE PRESSURE AND ROOM TEMPERATURE UNLESS OTHERWISE SPECIFIED. PRESSURE MEASUREMENTS ARE WITH POSITIVE PRESSURE APPLIED TO PORT B.

NOTE 2: SHIFT IS RELATIVE TO 25°C.

NOTE 3: SHIFT IS WITHIN THE FIRST HOUR OF EXCITATION APPLIED TO THE DEVICE.

NOTE 4: MEASURED AT ONE-HALF FULL SCALE RATED PRESSURE USING BEST STRAIGHT LINE CURVE FIT.

NOTE 5: THE VOLTAGE ADDED TO THE OFFSET VOLTAGE AT FULL SCALE PRESSURE.

Pressure Response: for any pressure applied the response time to get to 90% of pressure applied is typically less than 100 useconds.

All Sensors reserves the right to make changes to any products herein. All Sensors does not assume any liability arising out of the application or use of any product or circuit described herein, neither does it convey any license under its patent rights nor the rights of others.