



BLM Manifold Mount Bottom Pressure Sensors

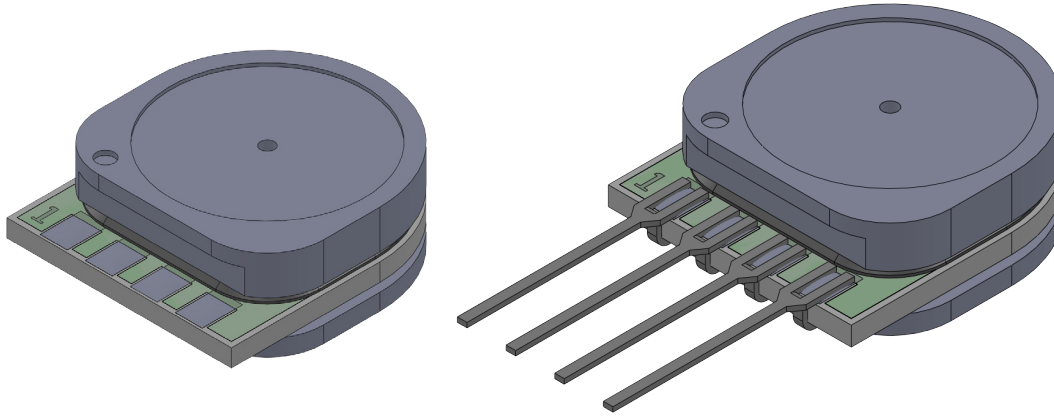

Table of Contents

Features & Applications.....	2
Pressure Sensor Maximum Ratings	2
Environmental Specifications.....	2
Equivalent Circuit.....	2
Standard Pressure Ranges	3
Performance Characteristics	4
How to Order Guide	5
Dimensional Package Drawings	6
Product Identification	6
Suggested Pad Layouts	6

Introduction

BLM Series pressure sensors use a silicon micromachined (MEMS) pressure sensor in the most basic configuration. The BLM Manifold package configuration provides a small footprint and manifold mounting.

This series is intended for use with non-corrosive, non-ionic working fluids such as air, dry gases and the like. The output of the device is ratiometric to the supply voltage. The BLM Series device provides an uncompensated output proportionate to pressure.

<https://www.allsensors.com/products/blm-series>



For All Sensors Corporation's most recent quality certification documents, please visit www.allsensors.com



BLM Manifold Mount Button Basic Pressure Sensors

Features

- Pressure Ranges from 1 inH₂O to 300 PSI
- 0.5% Linearity
- Manifold Mount
- ROHS Compliant

Applications

- HVAC
- Industrial Controls
- Environmental Controls

Wetted Media

- Silicon
- RTV
- Gold
- Ceramic
- Epoxy
- Nylon Plastic
- Aluminum

Pressure Sensor Maximum Ratings		Environmental Specifications	
Supply Voltage (Vs)	6 Vdc	Temperature Ranges	
Lead Temperature (soldering 2-4 sec.)	270°C	Operating	-25°C to 85°C
Device Temperature	245°C	Storage	-40°C to 125°C
		Humidity Limits (non condensing)	0 to 95% RH

Equivalent Circuit

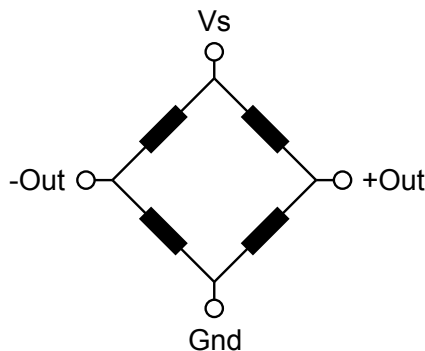

BLM Series Pressure Ranges

Operating Range ¹					Sensitivity			Proof Pressure ²		Burst Pressure ³	
					Min	Nominal	Max				
CODE	Pmin inH2O	Pmax	Pressure Mode	kPa	mV/V/Inch	mV/V/Inch	mV/V/Inch	inH2O	kPa	inH2O	kPa
BLM-L01G	0	1	Gage	0.2	2.2	4.5	6.7	270	67	415	103
BLM-L02G	0	2	Gage	0.5	2.2	4.5	6.7	270	67	415	103
BLM-L04G	0	4	Gage	1.0	1.4	2.9	4.3	300	75	500	124
BLM-L05G	0	5	Gage	1.2	1.4	2.9	4.3	300	75	550	137
BLM-L10G	0	10	Gage	2.5	0.9	1.8	2.7	350	87	550	137
BLM-L20G	0	20	Gage	5.0	0.4	0.9	1.3	350	87	550	137

CODE	Pmin PSI	Pmax	Pressure Mode	kPa	mV/V/PSI	mV/V/PSI	mV/V/PSI	psi	kPa	psi	kPa
BLM-001G	0	1	Gage	6.9	8.25	16.49	24.74	10	69	15	103
BLM-005G	0	5	Gage	34.5	4.00	5.32	6.64	10	69	15	103
BLM-015G	0	15	Gage	103.4	1.33	1.77	2.21	30	206	45	310
BLM-030G	0	30	Gage	206.9	0.67	0.89	1.11	60	413	90	620
BLM-060G	0	60	Gage	413.7	0.29	0.38	0.47	140	965	210	1447
BLM-100G	0	100	Gage	689.5	0.29	0.38	0.47	200	1379	250	1724
BLM-150G	0	150	Gage	1034.3	0.13	0.18	0.22	200	1379	250	1724
BLM-300G	0	300	Gage	2068.5	0.07	0.09	0.11	350	2413	350	2413

CODE	Pmin PSI	Pmax	Pressure Mode	kPa	mV/V/PSI	mV/V/PSI	mV/V/PSI	psi	kPa	psi	kPa
BLM-015A	0	15	Absolute	103.4	1.33	1.77	2.21	30	206	45	310
BLM-030A	0	30	Absolute	206.9	0.67	0.89	1.11	60	413	90	620
BLM-060A	0	60	Absolute	413.7	0.29	0.38	0.47	140	965	210	1447
BLM-100A	0	100	Absolute	689.5	0.29	0.38	0.47	140	965	210	1447
BLM-150A	0	150	Absolute	1034.3	0.13	0.18	0.22	200	1379	250	1724
BLM-300A	0	300	Absolute	2068.5	0.07	0.09	0.11	350	2413	350	2413

Note 1: Pressure ranges in Pa and kPa are expressed as an approximate value.

Note 2: Proof Pressure: The maximum pressure that may be applied to the sensor without causing any changes in performance to the specifications

Note 3: Burst Pressure: The maximum pressure the sensor is able to withstand before causing escape of the pressure media. The sensor should not be expected to function after exposed to any pressure beyond the burst pressure.



Performance Characteristics for BLM Series

Parameter	Min	Typ	Max	Units	Notes
Excitation					
1 inH ₂ O to 1PSI	-	2.8	6	V	Max: 1.8mA
>1PSI	-	5	15	V	Max: 3mA
Bridge Resistance					
1 inH ₂ O to 1PSI	2.5	3.2	3.8	kΩ	-
>1PSI	4	5	6	kΩ	-
Offset Voltage					
	-10	0	10	mV/V	-
Span					
L01G	6.3	12.5	18.8	mV	1
L02G	12.5	25	37.5	mV	1
L04G	16	32	48	mV	1
L05G	20	40	60	mV	1
L10G, L20G, 001G	25	50	75	mV	1
005G	100	133	166	mV	2
015G	100	133	166	mV	2
015A	100	133	166	mV	2
030A/G	100	133	166	mV	2
060G	86	114	142	mV	2
060A	86	114	142	mV	2
100A/G	143	190	237	mV	2
150G	100	133	166	mV	2
150A	100	133	166	mV	2
300A/G	100	133	166	mV	2
Temperature Effect on Offset					
1 inH ₂ O to 1PSI	-30	-	30	μV/V/°C	3
>1PSI	-25	-	25	μV/V/°C	-
Temperature Effect on Resistance					
1 inH ₂ O to 1PSI	2400	2800	3300	ppm/°C	3
>1PSI	2500	3000	3500	ppm/°C	-
Temperature Effect on Span					
1 inH ₂ O to 1PSI	-2500	-2000	-1600	ppm/°C	3
>1PSI	-2500	-2000	-1500	ppm/°C	-
Linearity Error					
1 inH ₂ O to 1PSI	-0.5	0.2	0.5	%FSO	4
>1PSI	-0.5	-	0.5	%FSO	4
Hysteresis Error					
	0.1	0	0.1	%FSO	4
Long Term Stability of Span					
	-	0.1	-	%FSO	-
Position Sensitivity					
L01G, L02G		0.035	0.075	%FSO/g	5
L04G, L05G		0.015	0.035	%FSO/g	5
L10G, L20G, 001G		0.010	0.025	%FSO/g	5

Specification Notes

Note 1: Measured at 2.8V constant voltage supply

Note 2 : Measured at 5V constant voltage supply

Note 3: Measured from 0-70°C

Note 4: Best Fit Straight Line @ 25°C

How to Order

For example, **BLM-L01G** defines an All Sensors' BLM Series Basic Manifold Mount Sensor, 1 inH₂O gage pressure range, BLM Manifold package with leads, whereas **BLM-L01G-L** defines an All Sensors' BLM Series Basic Manifold Mount Sensor, 1 inH₂O gage pressure range, leadless BLM Manifold package.

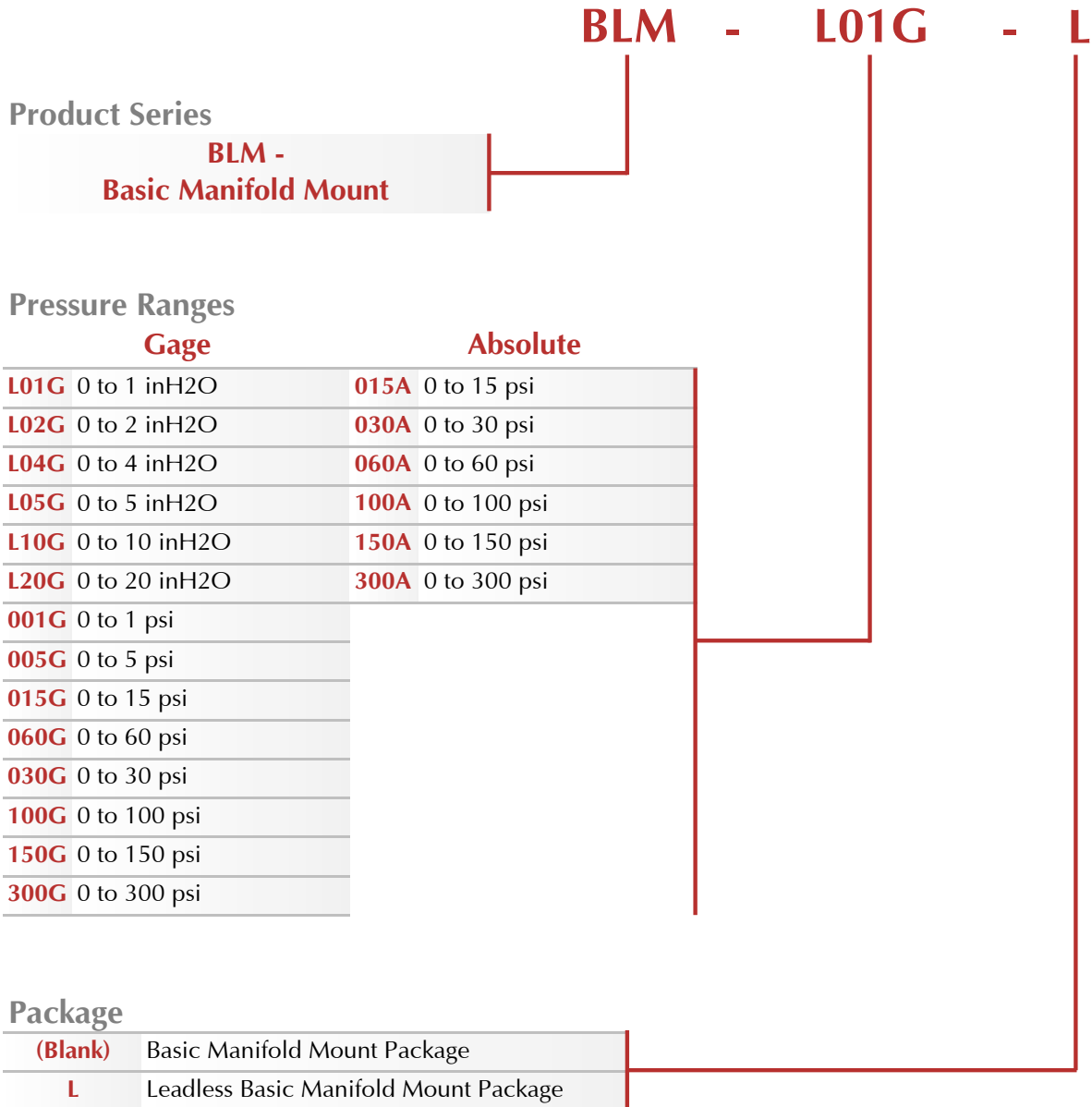

Dimensional Drawings

BLM Manifold Mount Package

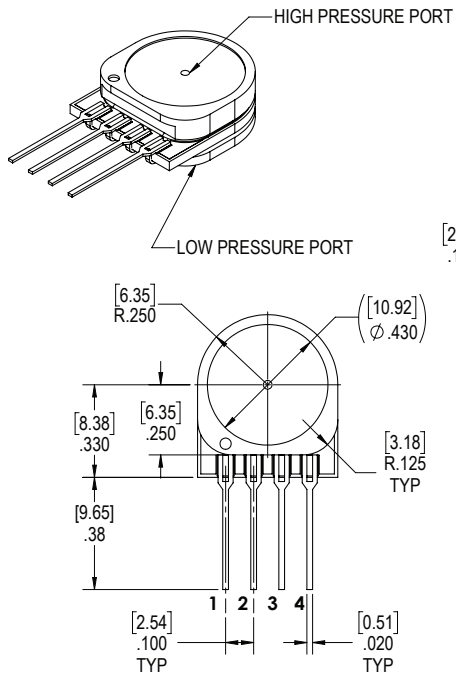

Pin	Definition
1	GND
2	Vout+
3	Vs
4	Vout-

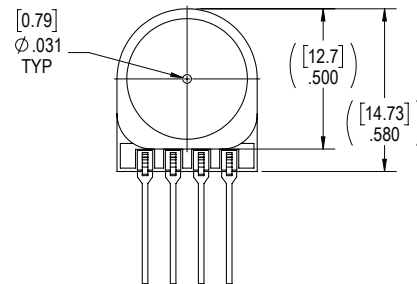
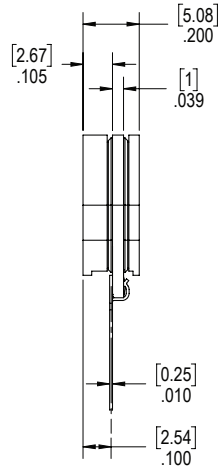

Notes

- 1) Dimensions are in inches [mm].
- 2) For suggested pad layout, see drawing: PAD-01.

ALL SENSORS

TITLE: BLM Series Package

SIZE FILE NAME
A BLM Basic Manifold Package

BLM Leadless Manifold Mount Package

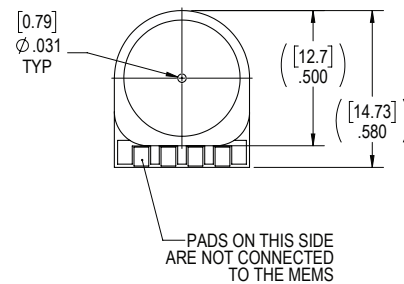
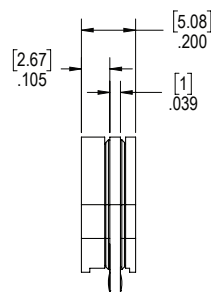
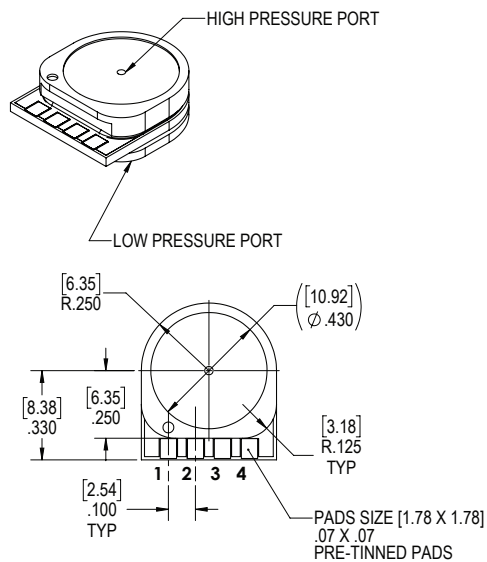

Notes

- 1) Dimensions are in inches [mm].

ALL SENSORS

TITLE: BLM Series Package

SIZE FILE NAME
A BLM Leadless Manifold Package

Product Identification

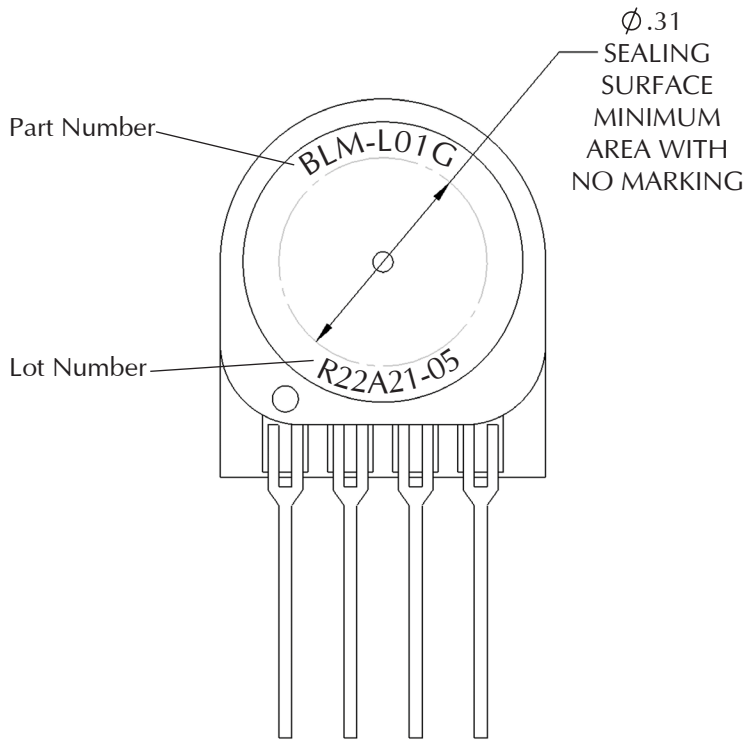

Suggested Pad Layouts

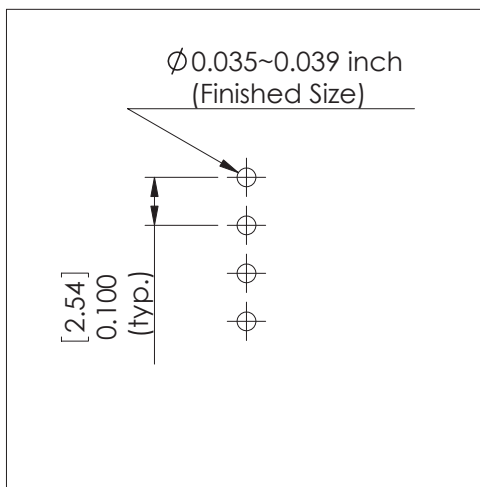

PAD-01

All Sensors reserves the right to make changes to any products herein. All Sensors does not assume any liability arising out of the application or use of any product or circuit described herein, neither does it convey any license under its patent rights nor the rights of others.